

(MACHINED FACE TO SUFFICIENTLY CLEAN UP OVER THIS DEPTH)

SECTION A-A (SCALE 1/1)

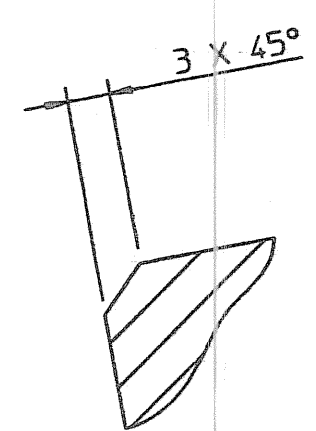

PART SECTION C-C (SCALE 2/1)

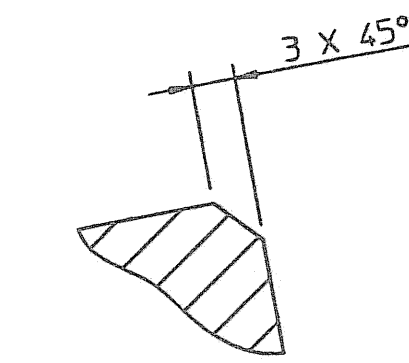

PART SECTION B-B (SCALE 2/1)

- NOTES.
- MATERIAL - CAST STEEL TO BS3100:1991 GRADE BT2.
 - HEAT TREATMENT TO GIVE THE FOLLOWING PROPERTIES -
 BRINELL HARDNESS 248-302
 UTS 850-1000 N/mm
 Y.P 585 N/mm MIN.
 ELONGATION 5.65 √So 8% MIN.
 CHARPY V-NOTCH, 25J @ 20°C.
 - TAPERED PATHWAY & VERTICAL EDGE TO BE MACHINED WITH RAIL FITTED ONTO A SPECIAL RIG.
 - RAIL SEGMENTS TO BE CAST WITH HEAD DOWNWARDS

ISSUE			ISSUE			ISSUE			ISSUE			ISSUE			ISSUE			UNLESS OTHERWISE SPECIFIED, IDENTIFY THE ITEM WITH THE DRAWING NUMBER AND ISSUE LEVEL AT # AND IN THE MANNER SHOWN, SYMBOL STANDARDS	MATERIAL AND CONDITION BEFORE MANUFACTURE	CLASSIFICATION	
ISSUE	DATE	BY	ISSUE	DATE	BY	ISSUE	DATE	BY	ISSUE	DATE	BY	ISSUE	DATE	BY	ISSUE	DATE	BY				DETAIL OF RAIL SEGMENT
DRAWN	CHECKED	APPROVED	DRAWN	CHECKED	APPROVED	DRAWN	CHECKED	APPROVED	DRAWN	CHECKED	APPROVED	DRAWN	CHECKED	APPROVED	DATE	DATE	DATE				
																			P101928		

UNLESS OTHERWISE SPECIFIED, IDENTIFY THE ITEM WITH THE DRAWING NUMBER AND ISSUE LEVEL AT # AND IN THE MANNER SHOWN, SYMBOL STANDARDS

FIRST ISSUE

DATE 24/09/1996
 CHECKED 30/09/1996
 APPROVED 30/09/1996

MASS 230 kg SCALE 1:1

STATUS APPROVED

UNLESS OTHERWISE STATED DIMENSIONS ARE IN MILLIMETRES.

TOLERANCES, UNLESS OTHERWISE STATED (PLUS OR MINUS)	RANGE	MACH	FAB	CAST
0-500	0.25	2	2	2
501-1000	0.5	3	3	4
1001-2000	1.0	4	4	6
ABOVE 2000	2.0	6	6	10

ASHTON HOUSE, PO BOX 103, ASHTON VALE ROAD, BRISTOL, BS99 7TJ, ENGLAND.
 TELEPHONE (0117)9664677. TELEX 44170. FACSIMILE (0117)9662605.

DETAIL OF RAIL SEGMENT

PART NUMBER P101928

DRAWING NUMBER 602402

SHEET 1 OF 1 ISSUE A