

CLASSIFICATION

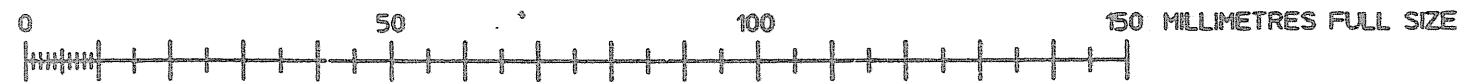

4375 REF

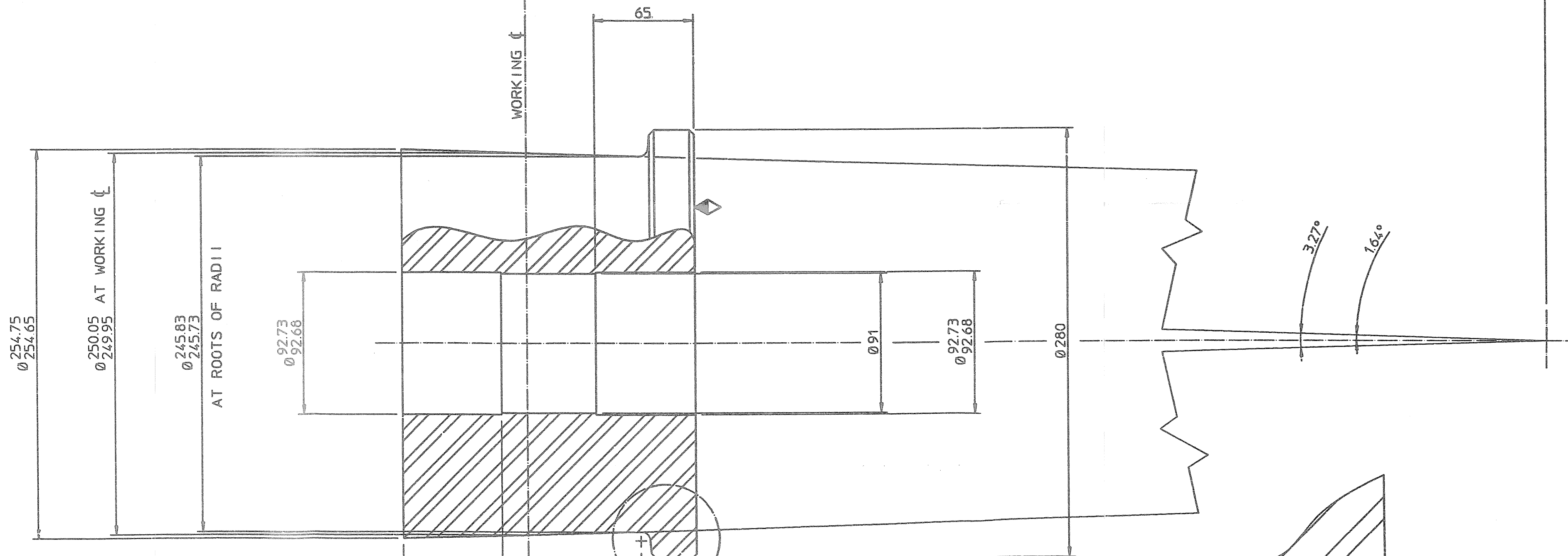

NOTES

1. MATL- STL TO BS970 GRADE 70M40
HEAT TREATED TO CONDITION T
TO GIVE-
 - A. TENSILE STRENGTH 87/102 Kg/mm²
 - B. YIELD STRESS 69 Kg/mm²
 - C. ELONGATION ON 5.65 $\sqrt{S_0}$ = 13%.
 - D. IZOD = 5.55 Kgm.
 - E. BRINELL = 248/302
2. M/C ALL OVER. ∇
3. TAPER ON ROLLER FACE- 1 IN 35(REF).
4. HARD MARK WHERE SHOWN THUS- \blacklozenge

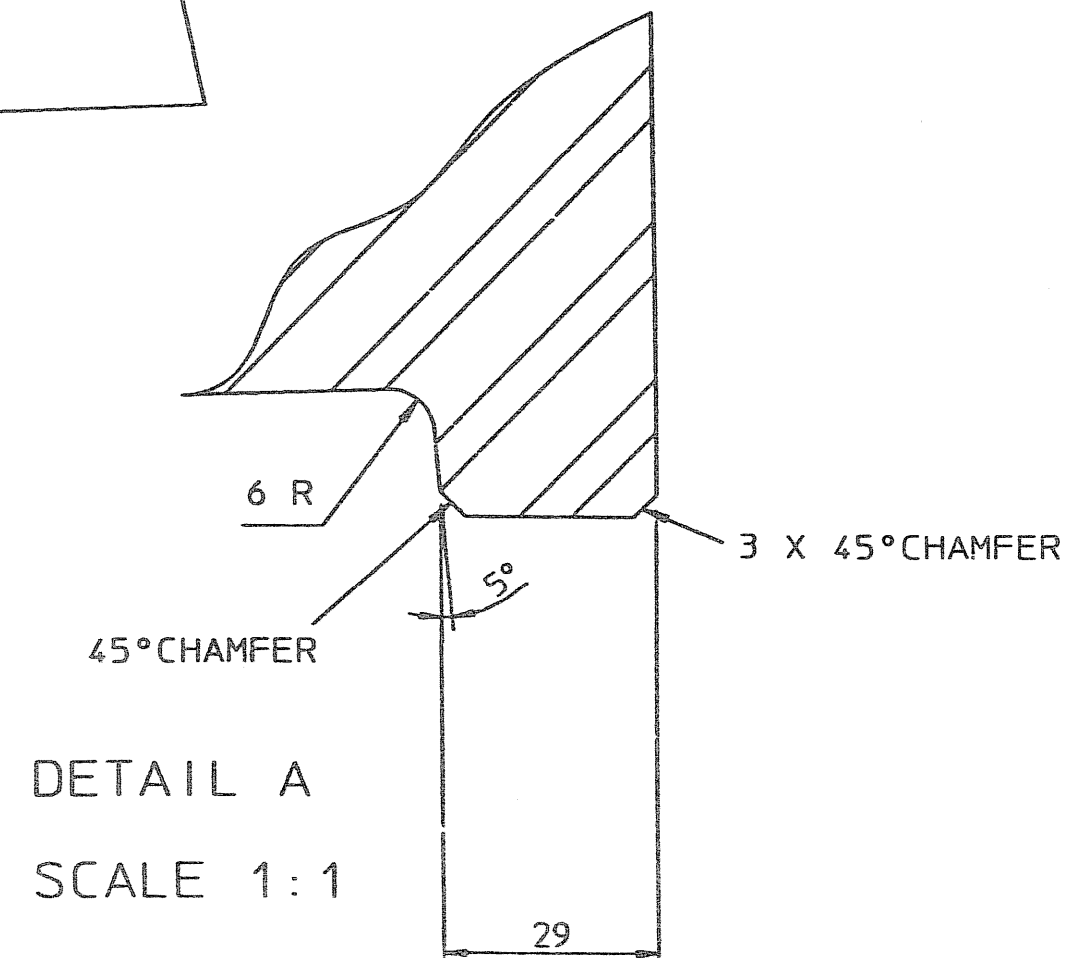

DETAIL A
SCALE 1:1

ISSUE



ISSUE



FIRST ISSUE

DRAWN	CHECKED	APPROVED	DRAWN	CHECKED	APPROVED
DAD	RPJ	RPJ	DAD	RPJ	RPJ
DATE	DATE	DATE	DATE	DATE	DATE
			23/09/1996	30/09/1996	30/09/1996

UNLESS OTHERWISE SPECIFIED, IDENTIFY THE ITEM WITH THE DRAWING NUMBER AND ISSUE LEVEL AT \blacklozenge AND IN THE MANNER SHOWN. SYMBOL STANDARDS

MATERIAL AND CONDITION BEFORE MANUFACTURE

MATL. SEE NOTES
SPEC.
GRADE
NOTES

CLASSIFICATION

All rights conferred by law or by international convention in this drawing and the design of the article depicted are reserved. This drawing and the design may also incorporate information which is confidential. Reproduction of the drawing and design and use and disclosure of the confidential information is prohibited, save as agreed by Strachan & Henshaw Limited or permitted by law.

UNLESS OTHERWISE STATED DIMENSIONS ARE IN MILLIMETRES.

TOLERANCES, UNLESS OTHERWISE STATED (PLUS OR MINUS)

RANGE	MACH	FAB	CAST
0- 500	0.25	2	2
501-1000	0.5	3	4
1001-2000	1.0	4	6
ABOVE 2000	2.0	6	10

STATUS APPROVED

MASS 70 kg

SCALE 1:2

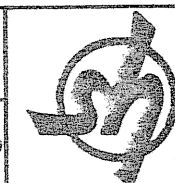

Strachan & Henshaw Ltd.

ASHTON HOUSE, PO BOX 103, ASHTON VALE ROAD, BRISTOL, BS99 7TJ, ENGLAND.
TELEPHONE (0117)9664677. TELEX 44170. FACSIMILE (0117)9662605.

TITLE

DETAIL OF ROLLER

PART NUMBER P101481

DRAWING NUMBER 602398

SHEET OF 1 1 ISSUE A