

date sheet

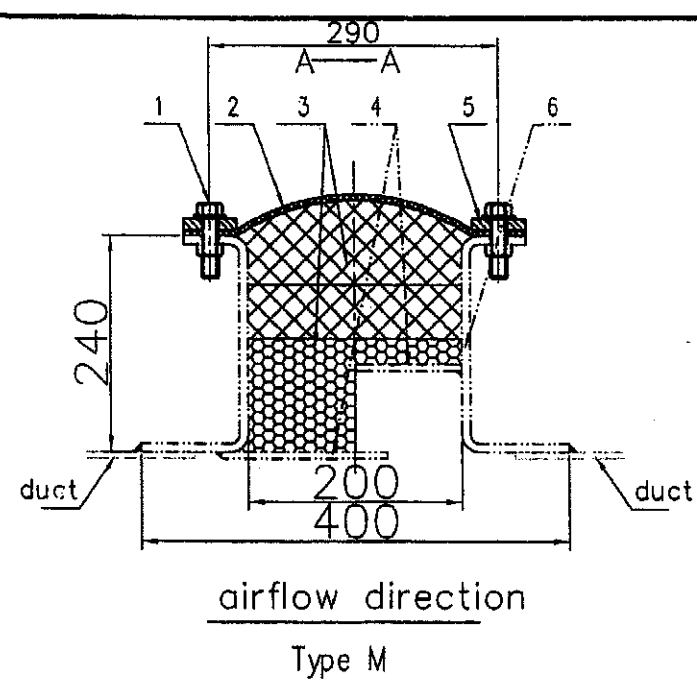

media specification	Raw flue gas
Design temperature ???	refer to 09MARITZA0B-00
Design pressure ?KPa?	refer to 09MARITZA0B-00
Axial compensation (mm)	refer to 09MARITZA0B-00
Lateral compensation (mm)	refer to 09MARITZA0B-00

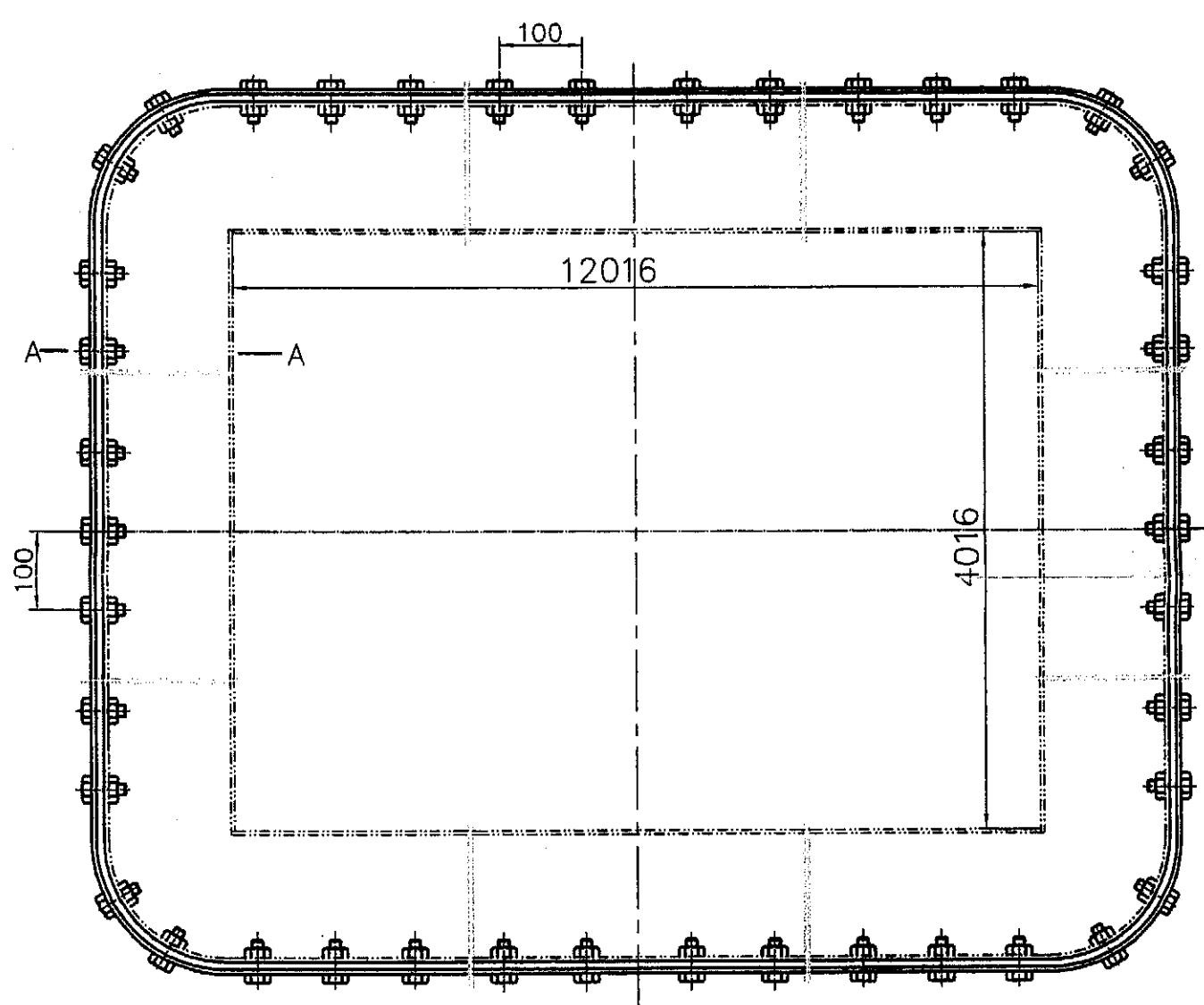

- Non-metallic expansion joint installation instructions?
1. Installing party conduct the ground assembly of the non-metallic expansion joint.
  2. Installing party are in charge of lifting and positioning of non-metallic expansion joint, and welding it with duct.;
  3. Installing party install the cover of the non-metallic expansion joint.

6	Flange		
5	Back up bars	Q235B(required SJ235)	thickness8mm
4	Baffle plate		
3	insulation cotton	Aluminum silicate cotton blanket	
2	Skin	Fluorine rubber	thickness4.0mm
1	Screw bolt assembly	carbon steel, galvanization	M16?80
No	Item	material	notes

DES.	LIUBIN	2010.03.16	ESP Inlet Raw Duct Expantion Joint	KKS
CHE.	LIULINA	2010.03.16		
AUD.				
APR.				
			Tender Units?WAH CHEONG TRADING	CO.

05HTA01AY01 05HTA02AY01  
06HTA01AY01 06HTA02AY01